



Partner in Growing



User Manual

Original document

Version 2015-1



Big Filler

Machine nr.:



© All rights reserved

The information provided herein may not be reproduced and/or published in any form, by print, photo print, microfilm or any other means whatsoever (electronically or mechanically) without the prior written authorisation of JAVO BV.

Preface

This user manual is written for anyone working on or with the machine. Before working on or with the machine, first read this manual.

This user manual contains important instructions / information on how to use the machine in a safe, professional and economical way and must always be available where the machine is used.

In addition to this user manual, the mandatory rules and regulations for accident prevention and environmental protection in the country and place of use of the machine must also be observed.

This user manual contains information on the operation of the machine with all the possible options. Use only the information that applies to your machine. Depending on the intensity of use and customer requirements, this machine can be equipped with various options. Contact your sales consultant.

Supplier details if not directly supplied by Javo BV. Dealer stamp:



Javo BV is not responsible for any errors in this manual or the consequences thereof.

Javo BV is not liable for damage or consequential damage caused by operating errors, lack of expert maintenance and any use other than described in this manual.

The liability of Javo BV also expires once modifications or additions are made without written permission of Javo BV.

This machine is suitable for process and environmental conditions as stated in section "Specifications and Tolerances" of this manual. Any other use is not authorized by Javo BV and this allows the operator and / or its environment at risk.

Table of contents

1	Technical specifications and tolerances	3
1.1	Type plate.....	3
2	Safety	4
2.1	Provisions	4
2.2	Safety devices on the machine	5
2.3	Explanation of icons and symbols.....	5
3	Description of the machine	6
3.1	Machine overview	6
3.2	Options.....	6
3.3	Operation	6
3.4	Machine workstations.....	6
3.5	Controls	6
4	Transport	7
5	Mounting, installation and commissioning	8
5.1	Placement	8
5.2	Facilities to take care of by the user	8
5.3	Mounting / Connecting.....	8
5.4	Check elevator rotation direction	9
5.5	Check elevator chain tension	9
5.6	Check substrate conveyor tension.....	9
5.7	Set substrate conveyor speed.....	10
5.8	Set substrate discharge.....	10
5.9	Set the substrate level sensors (optional)	10
6	Operation	11
6.1	Start.....	11
6.2	Stop	11
6.3	Emergency stop.....	11
7	Maintenance	12
7.1	Required tools and equipment	12
7.2	Preventive Maintenance	12
7.3	Test safety circuit	13
7.4	Fault list.....	13
7.5	Drawings and schemes.....	14
7.6	Spare parts	14
7.7	JavoNet.....	14
7.8	Customer support and advice.....	14
8	Disposal of machine or machine parts	14
9	EG-conformity statement	15

1 Technical specifications and tolerances

This machine is intended to be used for transporting substrate from a conveyor belt through an elevator and dumping it for the next process only. This machine is meant for processing substrate and other materials that are described in this manual only. Detailed operation of the machine is described in section "Operation".



This machine may be used only within the limits for specifications and tolerances of the order, on the assembly drawing and indicated in this manual. If the machine is used outside these specifications, Javo BV cannot take responsibility for this machine.



This machine is intended for products as agreed in the order confirmation only. To ensure the proper operation of this machine, only products with specifications and tolerances as specified in the order may be used.



Do not use the machine for purposes other than the intended purpose of Javo BV. This can lead to damage and danger to the operator and its environment.



This machine is CE marked. When placing multiple machines in one line, the entire line must be properly CE marked before using this machine. Until proper CE Marking of the line is carried out, commissioning of this machine is prohibited.

Specifications	
Voltage	400Volt 50Hz 3~+N+ PE
Machine connection	16A 5pole
Power consumption	1,1 kW
Weight	± 775 kg
Height exit	915 mm
Length x width x height	4394 x 1580 x 2308 mm
Content substrate bin	± 3100 Litre
Year of construction	See type plate
Type product	As agreed in the order confirmation.

1.1 Type plate

The type plate is placed onto the main cabinet door.

Website: www.javo.se

E-Mail: info@tradgardsteknik.se

Type

Machine nr.

Bouwjaar

V kW

A Hz



2 Safety



This machine is built according the state of the art technique and the accredited safety regulations. Despite this, the body and life from the user or third parties can be in danger when using it. There could also arise damage to the machine or other goods when using it.



This machine is CE marked. When placing multiple machines in one line, the entire line must be properly CE marked before using this machine. Until proper CE Marking of the line is carried out, commissioning of this machine is prohibited.

2.1 Provisions

1. Operation and maintenance of this machine must be performed by qualified personnel in compliance with warnings on the machine and in accordance with the user manual. Keep children and other (unauthorized) persons away while using machine.
2. This machine is suitable for process and environmental conditions as stated in section "Specifications and Tolerances" of this manual only. Any other use is not authorized by Javo BV and this allows the operator and / or the environment at risk.
3. It is prohibited to modify this machine, without prior written approval of Javo BV.
4. Thermal fuses and torque limiters may not be set different upon delivery of the new machine. The thermal circuit breakers should never be used to turn on / off the machine.
5. This machine should be installed so that there is sufficient space remaining for providing safe instructions and / or performing maintenance and / or inspections. Put the brakes on the castors before the machine is turned on.
6. Keep the work area clean and well lit. Cluttered or dark areas invite accidents.
7. This machine is suitable to be used outside. Electrical components are only splash proof. Keep the machine away from rain and moisture. When using the machine in a humid environment is unavoidable, you should use an RCD.
8. Keep hands, hair, loose clothing and / or jewellery away from moving parts of the machine. Wear appropriate clothing without loose parts. Wear non-slip work shoes.
9. As long as the machine is on, no connection or safety devices may be removed. The machine may only be used when all protective devices and safety-related facilities are available and ready for use.
10. Do not stand on the machine when it is operating.
11. Never move the machine if the power cable and / or pneumatic supply is still connected.
12. Prescribed checks and maintenance in the user manual must be observed.
13. Allow the machine to be serviced and repaired by qualified personnel only with original replacement parts.
14. In addition to the user manual, generally applicable statutory and other regulations regarding accident prevention and environmental protection have to be respected. This is also referred to handling of personal protective equipment.
15. Inform operating personnel before start maintenance. Interrupt if possible the power (mains), before start machine investigation or maintenance by turning off the main switch and locking the main switch. Pull the plug from the wall socket.
 - a. As work must be done with power supply (mains) voltage on the machine, then arrange an additional person who can operate the emergency stop.
16. When a machine part is damaged or not working in the prescribed manner, the work must be interrupted immediately. Resumption allowed only when the machine part is repaired or replaced and checked. Consult your dealer if the machine is not functioning properly.
17. Machine and / or parts must be disposed in accordance with local laws and regulations.

2.2 Safety devices on the machine



Caps and doors are screening moving parts. Always place back caps and close doors before the machine is turned on. Caps and doors should remain closed while operating the machine.

The motors of the machine are protected against overload by thermal switches. These switches are located in the control box.

2.3 Explanation of icons and symbols

Pictogram	Meaning
	Read and understand this manual before using the machine and / or performing maintenance.
	Remove Power (mains).
	Wear during all work on or with the machine safety shoes and safety glasses.
	Wear during cleaning and maintenance work on this machine also safety gloves and protective clothing.
	Warning. Important points and / or instructions regarding safety and / or injury prevention are marked with this warning sign.
	Dangerous electrical voltage. Dangerous electrical voltage present.
	Risk of crushing. Danger of moving or rotating parts.
	It is forbidden to wear Loose clothing, long hair and / or jewelry nearby moving parts of the machine.
	Trespassing.
	Do not rinse control cabinet Danger of moisture in the cabinet when it is rinsed with water.

Symbols that may be present on this machine			
Drill 	Direction of movement 	Speed ground feeder (curved) 	Speed ground feeder (straight)
Speed pot belt (curved) 	Speed pot belt (straight) 	Brush disc Rotofill 	Tray belt Rotofill
Rotor Rotofill 			

3 Description of the machine

3.1 Machine overview

- A. Substrate bin
- B. Substrate conveyor
- C. Elevator
- D. Electrical cabinet
- E. Emission funnel
- F. Substrate level sensors (optional)



3.2 Options

Depending on the intensity of use and customer requirements, this machine can be equipped with various options. Contact your sales consultant.

Options	Code	Specifications
Big filler BIG		Elevator chain 6 vanes extended
Substrate bin increasement		
Substrate level control	NIVR	
Water dosing	GDUG	Spraybar

3.3 Operation

The process of the machine starts with the substrate bin, which is filled with substrate. Filling of the substrate bin can be done by means of a substrate conveyor, shovel, or be done manually.

By using the substrate conveyor belt, the substrate is transferred to the elevator. The elevator takes over the soil and transfers it to the emission funnel.

The machine is equipped with wheels, which makes the machine easy to move.

3.4 Machine workstations

This machine has no operator places.

3.5 Controls

At the electrical cabinet of the machine, these buttons and connectors are placed:

- A. Main switch / main power IN
- B. Emergency stop button
- C. Manual / Automatic
- D. Start / Stop

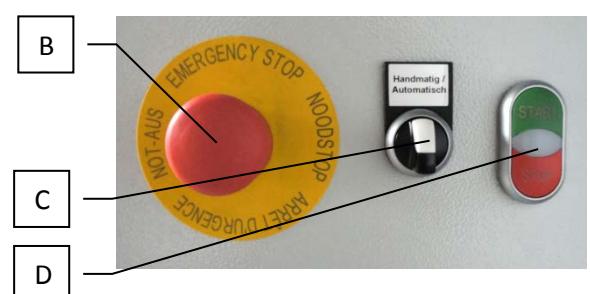

4 Transport



Follow all instructions described in this manual, in particular chapter safety.

On delivery of the machine, a Javo mechanical engineer must be present to unload the machine from the (freight) wagon.

Prior to moving the machine, the power should be disconnected. Make sure the cables are stowed sufficiently.

When moving within the company (when the machine does not need to be lifted) the state of the machine should be checked. Make sure the path to be traveled is free, so the machine can be moved to the desired position without obstacles.

If the machine is to be lifted for movement (outside the company), please contact your dealer or contact a professional shipping company.

The machine must be transported upright.

The relative humidity should not be too high so that water condenses in the machine.

Report damage during or immediately after delivery to the transport company and to Javo BV. Take all necessary steps to prevent further damage.

5 Mounting, installation and commissioning



Follow all instructions described in this manual, in particular chapter safety.



This machine is CE marked. When placing multiple machines in one line, the entire line must be properly CE marked before using this machine. Up to CE Marking of the line, commissioning of this machine is prohibited.

5.1 Placement

The machine must be placed on a flat surface, with sufficient weight capacity. Install the machine so that there is enough space left for service providing, safe instructions and / or cleaning, maintenance and / or inspections. Put the brakes on the castors before the machine is turned on.



This machine is not suitable to be used in the open air. Electrical components are only splashproof. Keep the machine away from rain and moisture. When using the machine in a humid location is unavoidable, you should use an RCD.

5.2 Facilities to take care of by the user

Prior to delivery of the machine, the required materials and facilities (power, etc.) needs to be present within 3 meters of machine.

Required power supply: 400 Volt, 3 Phase + Neutral + Earth. (N. America: 208/220V 60Hz.).

5.3 Mounting / Connecting

If applicable, the components supplied are to be mounted on the machine. Make sure that the moving parts are free. If the machine is complete, it can be connected (by a competent person) to the power supply.



Keep hands, hair, loose clothing and / or jewellery away from moving parts of the machine. Wear appropriate clothing without loose parts. Wear non-slip work shoes.



As long as the machine is on, no connection or safety devices may be removed. The machine may only be used when all protective devices and safety-related facilities are available and ready for use.

5.4 Check elevator rotation direction



Check the rotation direction of the elevator before you start working with the machine.

Procedure:

1. Connect the power cable.
2. Start the elevator.
 - a. Turn on the main switch.
 - b. Press the reset button emergency stop circuit.
 - c. Start the elevator with the elevator button.
3. Check the direction of rotation of the elevator.
 - a. The desired direction of rotation shown in the picture.
4. Stop the elevator by turning the elevator switch off.
5. Turn the main switch off.
6. When rotation direction is incorrect:
 - a. Remove the plug from the socket.
 - b. Open the plug and switch 2 of the 3 phases in the plug. This should only be carried out by suitably qualified personnel.



5.5 Check elevator chain tension



Check the elevator chain tension before you start working with the machine.

Procedure:

1. Check the elevator chain tension. The correct tension is obtained when the chain in the middle deflects $\pm 10\text{mm}$.
2. Adjust the chain tension if necessary .
 - a. The tension can be adjusted using the two clamping nuts, located on both sides of the elevator housing.
 - b. Loosen tightening nuts (A).
 - c. Tighten the nuts (B) on both sides of the elevator equally.
 - d. Tighten tightening nuts (A).

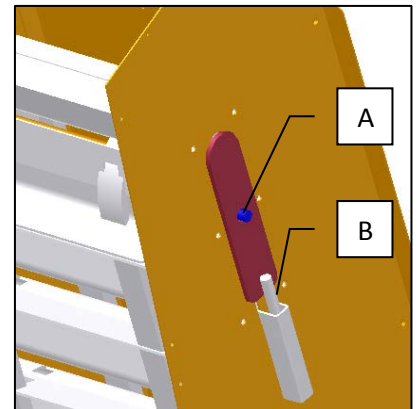

The tension of the chain should not be too tight.

5.6 Check substrate conveyor tension



Check the substrate conveyor belt tension before you start working with the machine.

Procedure:

1. Check the substrate conveyor belt tension. The correct tension is obtained when the belt in the middle deflects $\pm 40\text{mm}$.
2. Adjust the belt tension if necessary .
 - a. Loosen the four screws (B) to the block bearings.
 - b. The tension can be adjusted by simultaneously turning both sides of the ground belt (A).
 - c. Tighten the four screws (B) to the block bearings.

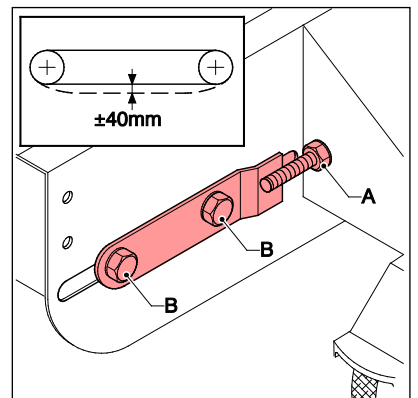

5.7 Set substrate conveyor speed



Set the substrate conveyor speed before you start working with the machine.

Procedure:

1. Check the substrate conveyor speed. Set the speed in this way that trays are being filled sufficiently before they reach the substrate slide.



Adjust the speed of the conveyor belt as slowly as possible. Do not add more soil than necessary.



Adjust the speed of the conveyor belt only when engines are running.

2. When the speed needs to be adjusted:
 - a. Loosen locking bar (A).
 - b. Turn wheel (B):
 - i. CCW = substrate conveyor speed is increased.
 - ii. Clockwise = the speed of the conveyor will run slower.
 - c. Tighten locking bar (A).

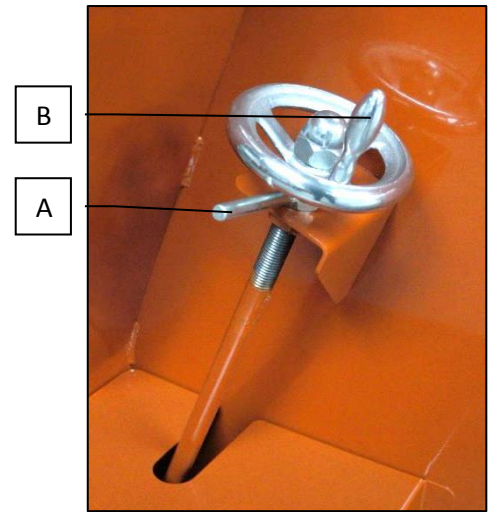

5.8 Set substrate discharge



Set the substrate discharge before you start working with the machine.

The emission funnel can be set forward or backward.

procedure:

1. Loosen the two star knobs (A).
 - a. Pull the emission funnel backwards or forwards.
2. Loosen the two star knobs (A).

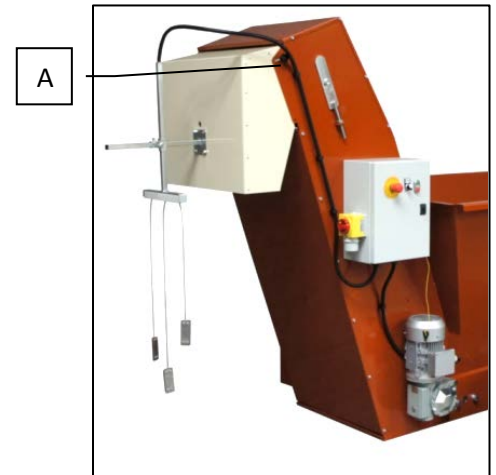

5.9 Set the substrate level sensors (optional)



Set the substrate level sensors before you start working with the machine.

The substrate level sensors (A) hang in the substrate bin of the coupled machine. These ensure that if the substrate level is too low, substrate to replenishment. The substrate level sensors are adjustable in height and depth.

procedure:

1. Loosen the cross piece M8 bolts (B).
 - a. The level sensors can now be adjusted in height and depth.
2. Tighten the cross piece M8 bolts (B).

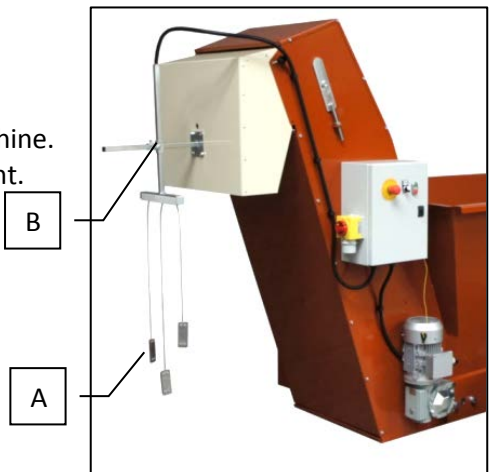

6 Operation



Follow all instructions described in this manual, in particular chapter safety.



Keep hands, hair, loose clothing and / or jewelry away from moving parts of the machine. Wear appropriate clothing without loose parts. Wear non-slip work shoes.



As long as the machine is on, no connection or safety devices may be removed. The machine may only be used when all protective devices and safety-related facilities are available and ready for use.



If a machine part is damaged or not working in the prescribed manner, work must be interrupted immediately. Resumption allowed only when the machine part is repaired or replaced and checked. Consult your dealer if the machine is not functioning properly.

6.1 Start

The machine can be started in different ways, depending on the manner in which the machine is turned off in advance. The various options are explained below.

Start procedure:

1. Turn off the main switch (A) at the electrical cabinet.
2. Press the green button on the control panel to start the machine.



Automatic operation

By switching switch (C) to AUTO, the machine reacts to the substrate level sensors. The machine will now automatically take care of giving the correct amount of substrate.

Manual operation

By switching and holding switch (C) to MANUAL, substrate is provided as long as the switch is held. The machine operator will have to remain at the switch to operate it.

C



6.2 Stop

Stop procedure:

3. Press the red stop button on the control panel.

6.3 Emergency stop

Emergency stop procedure:

1. Press the red emergency stop button on the machine to activate the emergency stop.

Restart after emergency stop procedure:

1. Ensure that the cause of the emergency is resolved.
2. Pull the red emergency stop button to reset.
3. Press the reset button.
4. Press the green button on the control panel to start the machine.



7 Maintenance



Follow all instructions described in this manual, in particular chapter safety.



Maintenance of this machine must be performed in compliance with warnings on the machine and in accordance with the user manual by qualified personnel.



Keep hands, hair, loose clothing and / or jewelry away from moving parts of the machine. Wear appropriate clothing without loose parts. Wear non-slip work shoes.



As long as the machine is on, no connection or safety devices may be removed. The machine may only be used when all protective devices and safety-related facilities are available and ready for use.



Always unplug the plug from the socket before starting maintenance. Wear personal protective equipment (see section 2.3).



Inform operating personnel before start maintenance. Interrupt if possible the power (mains), before the machine is investigated or maintained by turning off the main switch and locking it and pull the plug from the socket. If work must be done with power supply (mains) voltage on the machine, work with an additional person who can operate the emergency stop.

7.1 Required tools and equipment

A set of keys is included with the machine, consisting of:

- A. Door key
- B. Spanner 24-27mm
- C. Spanner 17-19mm
- D. Spanner 10-13mm

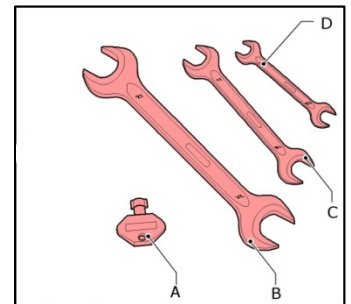

7.2 Preventive Maintenance

For the following maintenance instructions normal use is considered. With heavy use, or use under extreme conditions, maintenance should be performed at shorter intervals.

Item	1x per...	Comments
Machine	Day	Check if moving parts are functioning correctly and not clamping and / or parts are broken or damaged in such a way that the operation is adversely affected. Have damaged parts repaired before use.
Machine	Day	Cleaning. Spray with compressed air; Never clean with water. Spray the machine thoroughly so that excess substrate cannot stick.
Chain and conveyor	Day	Check tension. See section "Mounting, installation and commissioning".
Safety components	Week	Test the safety circuit. See section "Test safety circuit".
Pictograms	Week	Check readability and replace if necessary.
Bearings	320 hours	Grease with a grease gun 1 to 2 strokes of grease to each grease fitting.
Electrical installation	Year	Check for damage.
Electric motors	Year	Remove dust.

7.3 Test safety circuit

Procedure:

1. Start the machine.
2. Press the emergency stop button. The machine is now disabled.
3. Pull the Emergency Stop button. The machine remains off.
4. Press the reset button emergency stop circuit. All possibly connected conveyors start moving.
5. Start the machine



The machine must not be used when going through the above process, the machine responds differently than described above. Warn directly Javo BV.

7.4 Fault list

Problem	Possible cause	Action / Solution
Motor fault	mains voltage deviates more than 10% of the rated motor voltage	Provide the correct voltage
	Too high cooling air temperature	Provide cool air
	Poor cable connection	check the cable connection and repair if necessary
	Blown fuse	Replace fuse
	Too little cooling air caused by a clogged cooling air passage	Ensure proper inlet and outlet of the cooling air
The motor hums and takes too much power	Defect winding	Repair or replace the motor winding
Thermal fuses are falling out	Motor defect	Call a mechanic
	Mechanical blockage of elevator	Remove blockages
	Motor is connected incorrectly	Connect the motor correct
Soil conveyor is not moving	The motor or mechanical drive is not functioning	Check motor and drive mechanism
	Conveyor tension is too low (belt slipping)	Increase conveyor belt tension
The elevator chain does not move	Obstacles in chain	Remove obstacles
	Ground freezes in elevator	Remove excess soil from elevator paddles
Machine does not start	Emergency stop button is not pulled	Pull Emergency Stop button and reset the safety circuit by pressing the reset button
	Breaker tripped in main cabinet	See why circuit breaker has tripped. Remove obstacles to conveyors. Switch on the machine after solving the problem.
	Cable length too large causing voltage loss	Reduce cable length
	Voltage fluctuations caused by other devices on the same group	Ensure the correct voltage. Turn off other devices
	A second in-line machine is not ready so that the emission is not released	Clear the emission in second machine in line.
Amount of soil provided is not enough	belt slipping	Check conveyor tension

7.5 Drawings and schemes

The drawings accompanying this machine are supplied in a separate file. The wiring diagrams are included in the electrical cabinet of the machine.

7.6 Spare parts

Only original spare parts and accessories of Javo BV may be used on the machine.

Javo BV advises you to take certain parts in stock because of wear sensitivity and / or any expected downtime for re-ordering of the parts.

The spare parts list can be found on the assembly drawings. These can be found on JavoNet.

When ordering (spare) parts at Javo BV, the following information must be included: drawing number, item number, desired length (if applicable) and the desired number of pieces.

7.7 JavoNet

We recommend you to register your machine on JavoNet. This way you get online access to all technical drawings and documents pertaining to your machine.

Visit our website (www.javo.se) for more information and to request an account.



7.8 Customer support and advice

Our technical department will answer your other questions about repair and maintenance of your machine and spare parts. We can help you with any questions regarding the purchase, use and settings of products and accessories.

8 Disposal of machine or machine parts



Follow all instructions described in this manual, in particular chapter safety.

Perform the following steps when disposing the machine:

1. Decommission the machine and remove electric and pneumatic power.
2. Drain and remove all consumables.
3. Scrap the machine according to the local legislation.

9 EG-conformity statement

EG-conformity statement for machines (directive 2006/42/EG, annex II, under A.)

TRÄDGÅRDSTEKNIK AB
Helsingborgsv., Varalöv
262 96 ÄNGELHOLM

Declares that:

Machine: **Big Filler**
Type: **Substrate system**

is in accordance with the **Machine directive 2006/42/EG** and complies with the provisions of the **EMC-directive 2004/108/EEG**

Complies with the harmonized European Standards:

Harmonized European standard	definition	Harmonized European standard	definition
NEN-EN-ISO 12100:2010	Safety of machinery - Basic concepts, general principles for design - Part 1: Basic terminology, methodology	NPR-ISO/TR 14121-2:2010	Safety of machinery - Risk assessment - Part 2: Practical guidance and examples of methods
NEN-EN-ISO 13857	Safety of machinery - Safety distances to prevent hazard zones being reached by the upper and lower limbs	NEN-EN-IEC 60204-1	Safety of machinery - Electrical equipment of machines - Part 1: General requirements