



JAVO BIG BALE (GDU)

Specifications:

Voltage	400Volt 50z 3~+N+ PE (N. America 208/220V. 60Hz)
Power connection machine	16A 3 phase 5pin
Power	2.25kW
Length	3.480mm (excl. Level control)
Width	1.696mm
Height	2.195mm
Weight	1.350kg
Free discharge height	830mm
Max. pallet width	1.200mm
Max. Bale height	2.500mm
Soil opener (Fluffer)	Opens structure of soil, adjustable in 6 steps
Maintenance set	16A plug, 3x open end wrench, 1x door key

Options:	Code:	Specifications:
4 meter 5x1.5 cable incl. 16A plug	900965	
Continuos plug box	900966	Not standard
Level control	GDUN	Highly recommended on every Big Bale machine
Watering system	GDUG	Nozzle bar placed on the outlet Shute, incl. electrical valve and stop cock.
Extension set	200-180	350mm extra height
Heavy air wheels front side	GDUW	2, adjustable in height, wheels incl. transport bar
Solid swivel wheels back side	GDUW1	To be mounted on Transport bar (not included)

Notes:

- Width outflow 778mm on a height of 830mm
- Width outflow 1350mm on a height of 1180mm
- On January 4th, 2001 the machine has been widened from 1.100mm to 1.200mm.
- Bottom shaft has been removed out of the Big Bale since January 2009 (bearings have been moved to the outside of the machine)

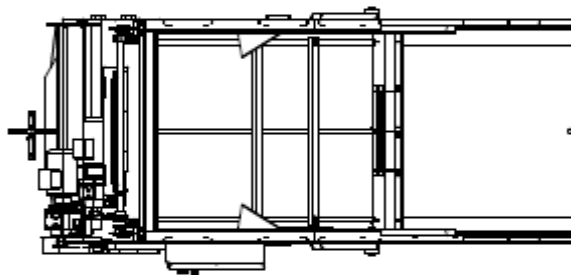
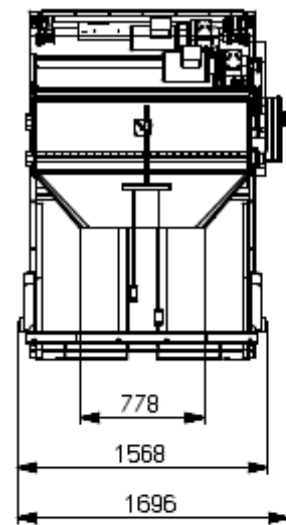
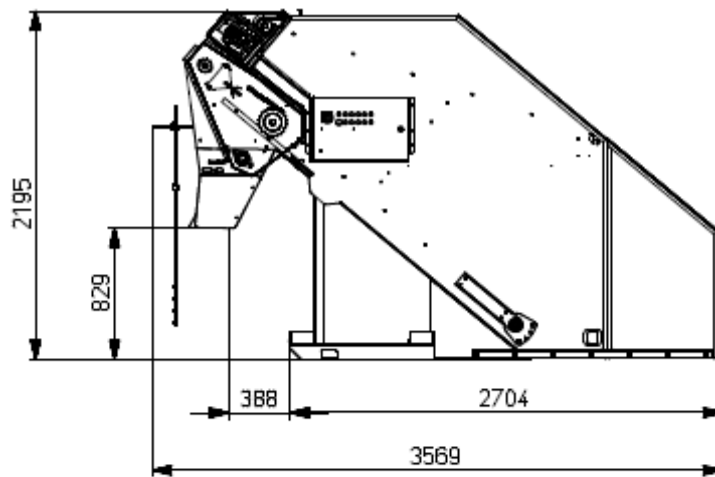

BIG BALE GEWONE GROND
230/400V 3Ph 50Hz

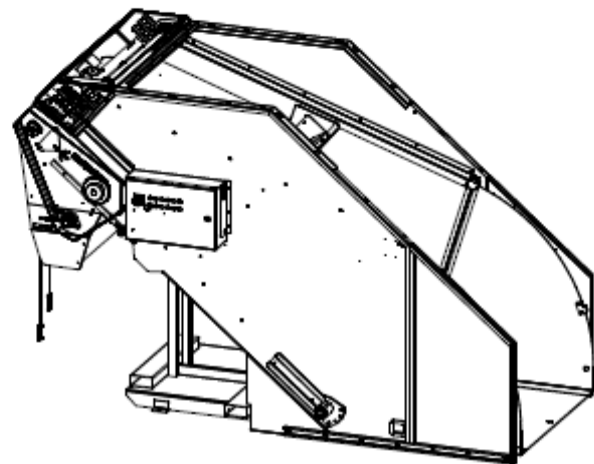



BIG BALE BARK (GDUB)

Specifications:

Voltage	400Volt 50z 3~+N+ PE (N. America 208/220V. 60Hz)
Power connection machine	16A 3 phase 5pin
Power	2.25kW
Length	3.480mm (excl. Level control)
Width	1.696mm
Height	2.195mm
Weight	1.350kg
Free discharge height	1.152mm
Width outflow	1.131mm
Max. pallet width	1.200mm
Max. Bale height	2.500mm
Maintenance set	16A plug, 3x open end wrench, 1x door key

Options:	Code:	Specifications:
4 meter 5x1.5 cable incl. 16A plug	900965	
Continuous plug box	900966	Not standard
Level control	GDUN	Highly recommended on every Big Bale machine
Watering system	GDUG	Nozzle bar placed on the outlet Shute, incl. electrical valve and stop tap.
Extension set	200-180	350mm extra height
Heavy air wheels front side	GDUW	2, adjustable in height, wheels incl. Transport bar
Solid swivel wheels back side	GDUW1	To be mounted on transport bar (not included)

Notes:

-First machine produced in January 2009.

Bottom shaft has been removed out of the Big Bale since January 2009 (bearings have been moved to the outside of the machine)

-No soil opener fitted.

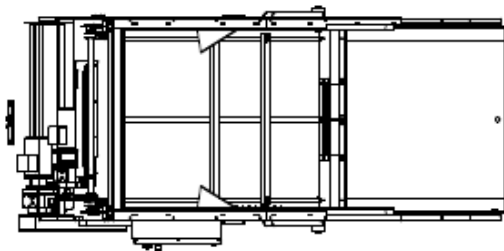
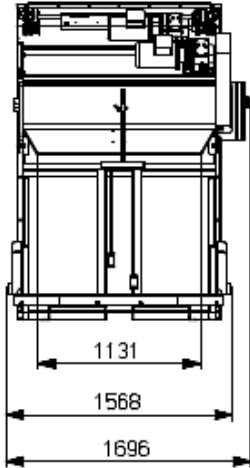
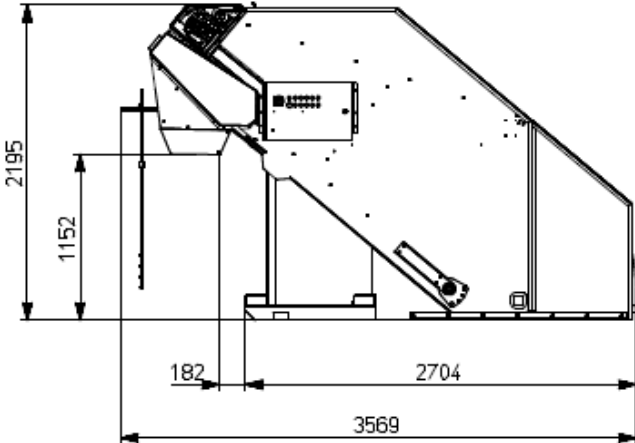

BIG BALE BARK
230/400V 3Ph 50Hz

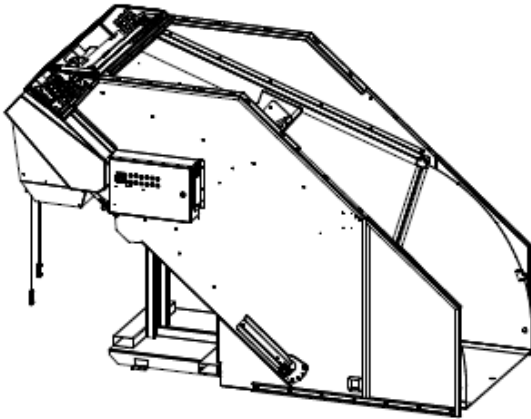

Oil quantities (ccm) variable-speed ball drive KR1-KR4

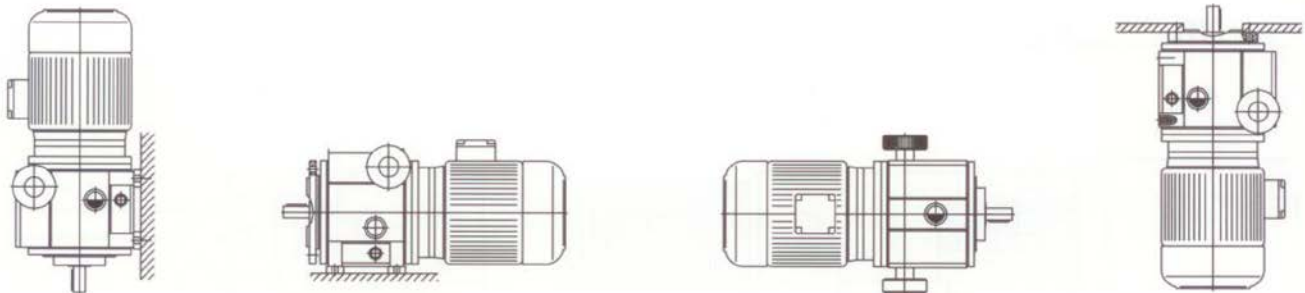

Einbaulage	V1, V5, V18	B3, B5, B14	B6, B7	V3, V6, V19
KR1	70	70	70	70
KR2	200	125	200	125
KR3	400	250	400	250
KR4	800	450	800	450

Only the use of Santotrac 50/Variotrac 32 synthetic traction fluid ensures full power transmission.

The warranty requires this oil type to be used. The oil should be changed after 5000 operating hours (at least once per year). The oil change must not be carried out during operation. No other maintenance work is required.

Oil quantities FMRV + FDL:

Drive:	Quantity (ltr):	Type:
FMRV030	0,05	BP Energol SG-XP320
FMRV040	0,1	BP Energol SG-XP320
FMRV050	0,15	BP Energol SG-XP320
FDL018	0,13 (aber in vertikal mit Wellenende nach unten: 0,2)	BP Autran DX
FDL037	0,15 (aber in vertikal mit Wellenende nach unten: 0,25)	BP Energol SG-XP320

Trädgårdsteknik AB
Helsingborgsvägen Varalöv
262 96 ÄNGELHOLM
Tel: 0431-22290
Fax: 0431-22270
Mail: info@[tradgardsteknik.se](mailto:info@tradgardsteknik.se)
Webb: www.tradgardsteknik.se