

# JAVO Bigbale

- ESR5

Versie 1  
12-11-2010

Wijziging				Datum	Naam	Norm	JAVO Bigbale				Voorblad Title sheet		Bigbale 2010		=		
				Datum			JAVO Bigbale				Voorblad Title sheet		Bigbale 2010		=		
				Eng.		FvK/RT	JAVO Bigbale				Voorblad Title sheet		Bigbale 2010		+		
				Gez.		28. Feb. 2011	JAVO Bigbale				Voorblad Title sheet		Bigbale 2010			Bl. 1	
				Norm			JAVO Bigbale				Voorblad Title sheet		Bigbale 2010			9 Bl.	





3.9/L3 → zt1  
 3.9/N → bw1  
 3.9/PE → gng12

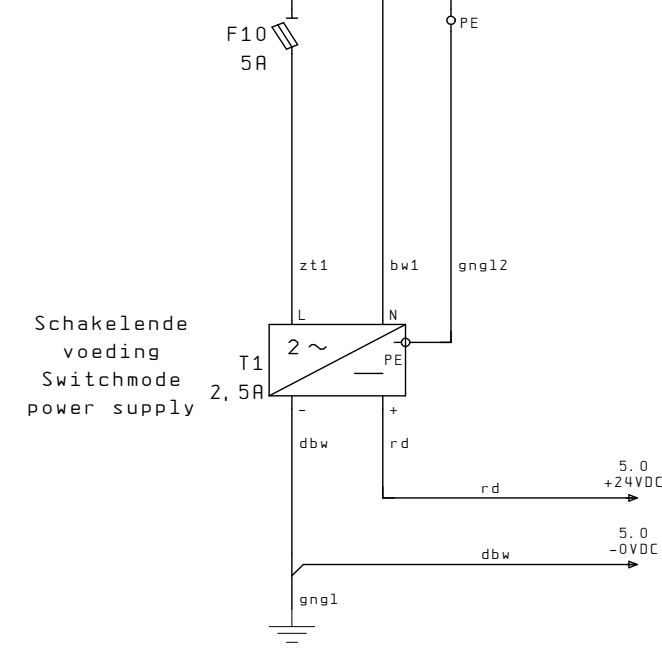

			Datum	
			Eng.	FvK/RT
			Gez.	28. Feb. 2011
Wijziging	Datum	Naam	Norm	

JAVO Bigbale



Hoofdstroom  
 Primary current

Bigbale 2010

=	
+	
B1.	4
	9 B1.

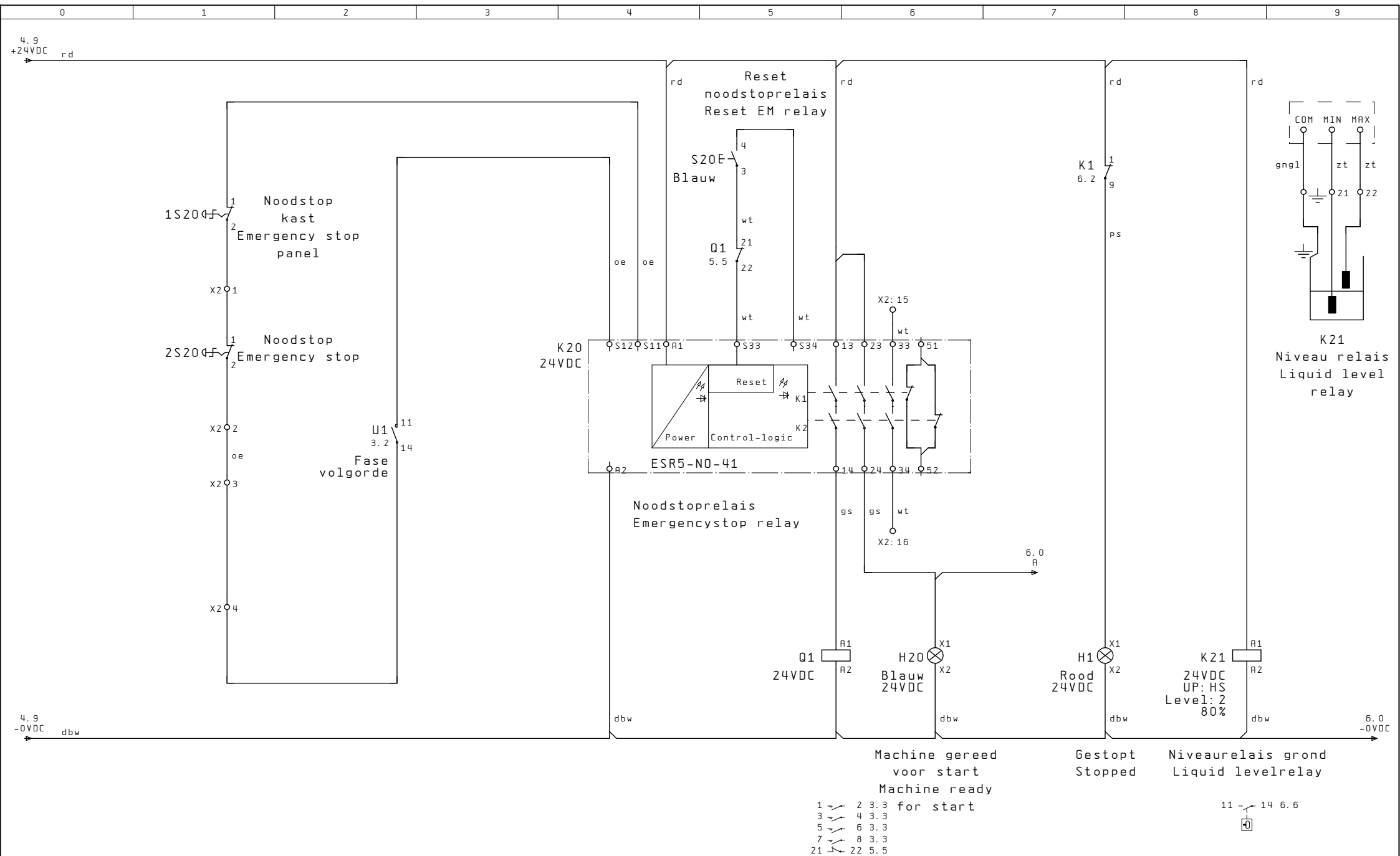

				Datum					
				Eng.	FvK/AT				
				Gez.	28. Feb. 2011				
Wijziging	Datum	Naam	Norm	JAVO Bigbale				Stuurstroom Control voltage	
				Bigbale 2010				=	
								+ B1. 5	
								9 B1	



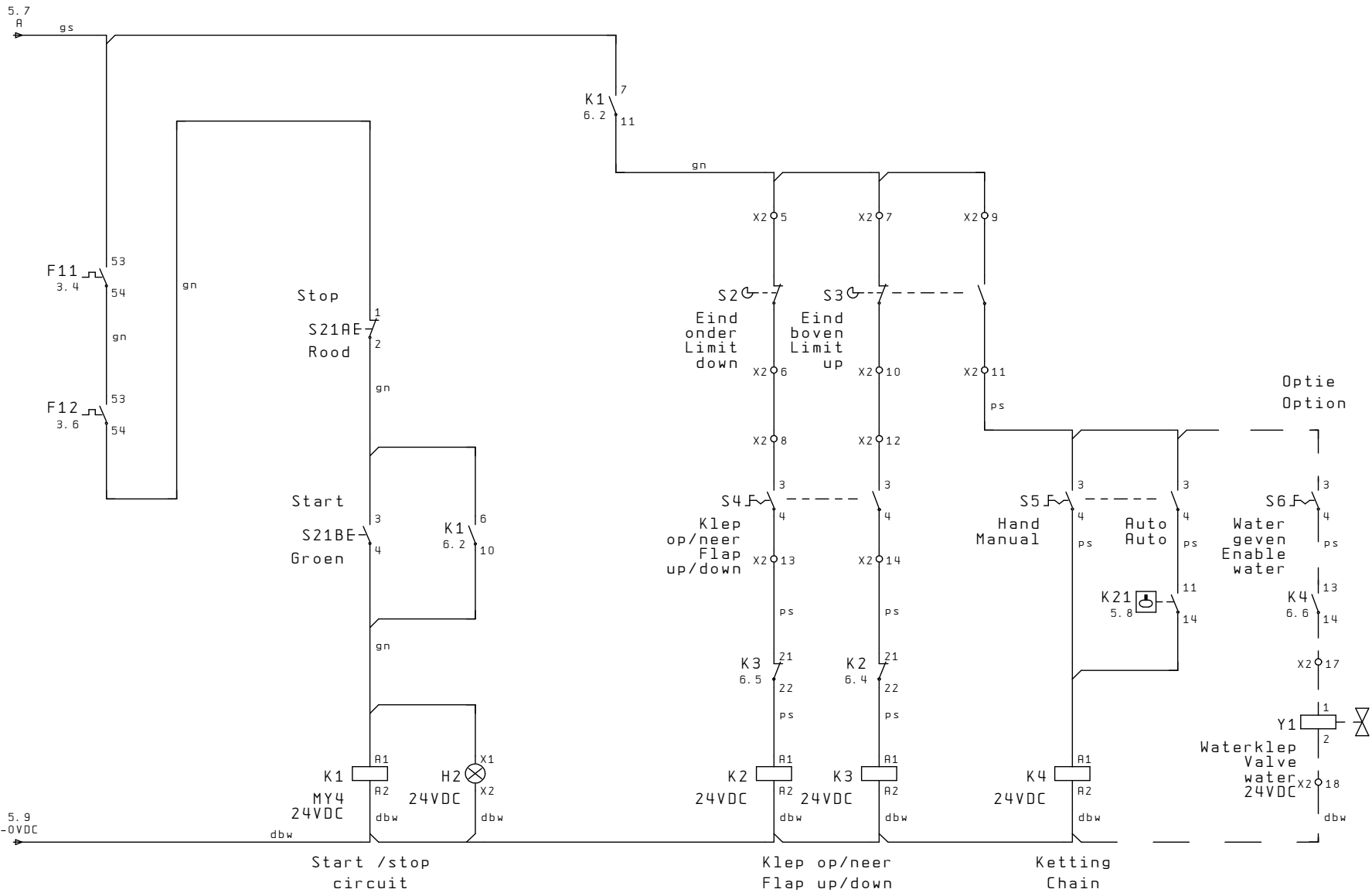

Start /stop circuit

Klep op/neer Flap up/down

Ketting Chain

- 1 ↗ 9 5.7
- 6 ↗ 10 6.2
- 7 ↗ 11 6.3

- 1 ↗ 2 3.6
- 3 ↗ 4 3.6
- 5 ↗ 6 3.6
- 13 ↗ 14 3.8
- 21 ↗ 22 6.5
- 1 ↗ 2 3.7
- 3 ↗ 4 3.7
- 5 ↗ 6 3.8
- 13 ↗ 14 3.8
- 21 ↗ 22 6.4

- 1 ↗ 2 3.4
- 3 ↗ 4 3.4
- 5 ↗ 6 3.5
- 13 ↗ 14 6.7

				Datum											
				Eng.	FvK/RT				JAVO Bigbale		TAVO HOLLAND		Stuurstroom Control voltage		
				Gez.	28. Feb. 2011						Bigbale 2010		=		
				Wijziging	Datum	Naam	Norm							B1. 6	
														9 B1	









Trädgårdsteknik AB  
Helsingborgsvägen Varalöv  
262 96 ÄNGELHOLM  
Tel: 0431-22290  
Fax: 0431-22270  
Mail: info@[tradgardsteknik.se](mailto:info@tradgardsteknik.se)  
Webb: [www.tradgardsteknik.se](http://www.tradgardsteknik.se)