

# Air consumption cylinders/machines

## Air consum. cylinders measured at 3.000 strokes p/h at 6 atm. (90psi)

Length Cylinder	Diameter 12	Diameter 20	Diameter 32	Diameter 40
300mm			156 NL/minute	243 NL/minute
250mm			130 NL/minute	202,5 NL/minute
200mm			104 NL/minute	
150mm			78 NL/minute	
100mm		20,5 NL/minute	52 NL/minute	
70mm		14,35 NL/minute		
50mm		10,25 NL/minute		
20mm	1,38 NL/minute	4,1 NL/minute		
16mm	1,1 NL/minute	3,3 NL/minute		
12mm	0,83 NL/minute	2,5 NL/minute		

## Air consumption in NL/minute per item

Machine	Measured speed	NL/minute
POP pot dispenser	3000 strokes per hour	10,25
LPO large pot dispenser	3000 strokes per hour	39,75
Osmocote dispenser*	1500 strokes per hour	52
Blowers continuous**	N.a.	262
Blowers per stroke	3000 strokes per hour	56,50
Placing robot NZ0-1 + staggering***	500 strokes per hour	83,50
Pick-up robot NZ100 + staggering***	500 strokes per hour	4,3
Compact pick-up NZL100	500 strokes per hour	
Compact placing NZL0-1	500 strokes per hour	
Linea Recta pick-up NZLR100	500 strokes per hour	
Linea Recta placing NZLR0-1	500 strokes per hour	

### Notes:

**NL = Nominal Liter p. m. x 0.264= gallon p.m. (GPM) : 7.48 = Cubic feet p. m. (CFM)**

- Air consumption for a potting machine measured at 3,000 strokes per hour with a LPOD, AFLPR1, AFLA1 = 250 NL/minute (8.8 CFM)

- Intake capacity is mentioned in NL/minute.

\*The inner cylinder is adjusted at 2cm. (¾")

\*\* Not reduced, with a 2mm (3/32") blower opening

\*\*\* Staggering stroke at 100mm. (4")



*Partner in Growing*



## Newsletter

SUBJECT: Robot (214)

DATE: 13-08-09

The mounting bar for the staggered cylinder has been changed and made heavier. The bar used to be made of tube 80x30x2 and has now been changed to tube 80x30x3. Also the way of mounting has been changed; the end-plates stick out of the tube, so that the welding can be done all-round from the outside.

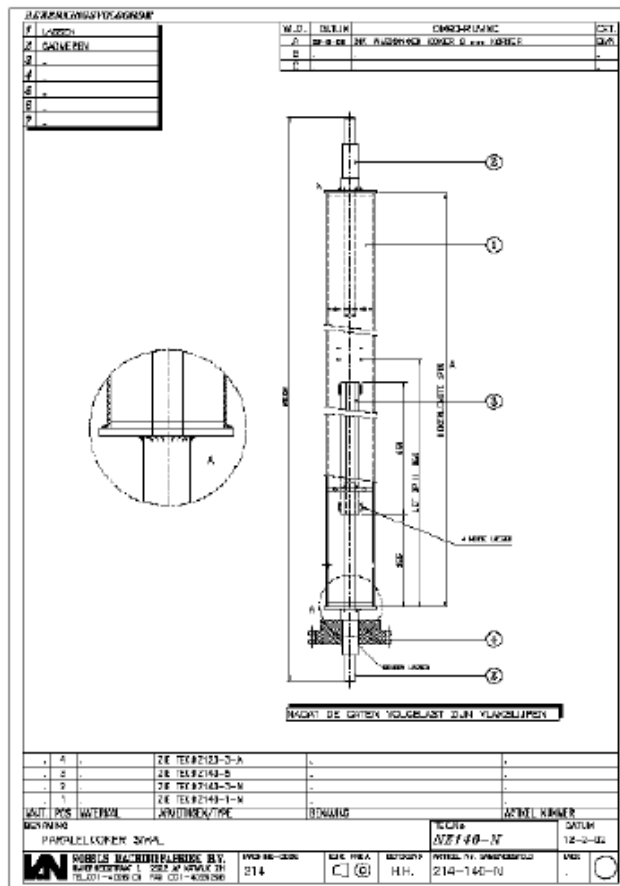





*Partner in Growing*



## ***Newsletter***

SUBJECT: Robot

DATE: 12-05-09

The mounted sensor plate in the large column of the robot will be replaced by a plate which can be disassembled and is adjustable in height. (214-148-A)

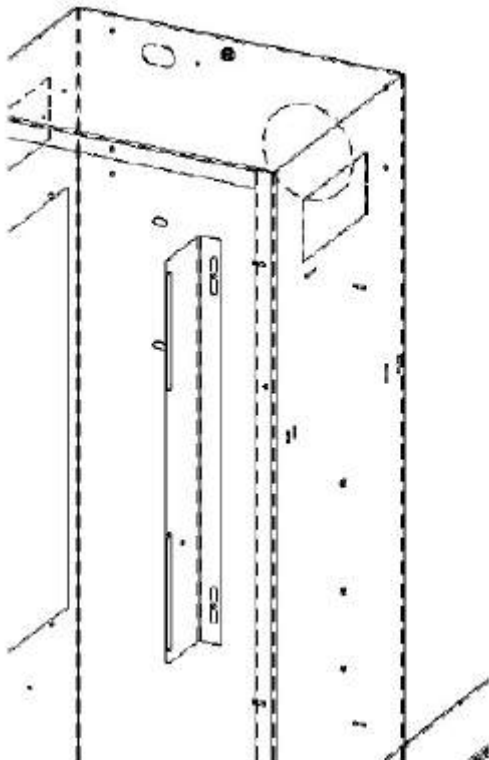

## Oil quantities (ccm) variable-speed ball drive KR1-KR4

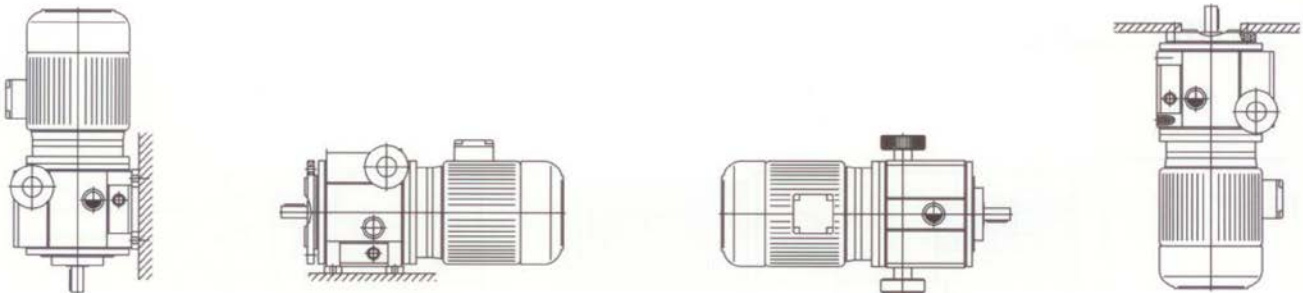

Einbaulage	V1, V5, V18	B3, B5, B14	B6, B7	V3, V6, V19
KR1	70	70	70	70
KR2	200	125	200	125
KR3	400	250	400	250
KR4	800	450	800	450

*Only the use of Santotrac 50/Variotrac 32 synthetic traction fluid ensures full power transmission.*

*The warranty requires this oil type to be used. The oil should be changed after 5000 operating hours (at least once per year). The oil change must not be carried out during operation. No other maintenance work is required.*

## Oil quantities FMRV + FDL:

Drive:	Quantity (ltr):	Type:
FMRV030	0,05	BP Energol SG-XP320
FMRV040	0,1	BP Energol SG-XP320
FMRV050	0,15	BP Energol SG-XP320
FDL018	0,13 (aber in vertikal mit Wellenende nach unten: 0,2)	BP Autran DX
FDL037	0,15 (aber in vertikal mit Wellenende nach unten: 0,25)	BP Energol SG-XP320

Trädgårdsteknik AB  
Helsingborgsvägen Varalöv  
262 96 ÄNGELHOLM  
Tel: 0431-22290  
Fax: 0431-22270  
Mail: info@[tradgardsteknik.se](mailto:info@tradgardsteknik.se)  
Webb: [www.tradgardsteknik.se](http://www.tradgardsteknik.se)