



## Inhoudsopgave / Index

Pagina 1	Voorpagina	Title sheet	Page 1
Pagina 2	Inhoudsopgave	Index	Page 2
Pagina 3	Hoofdstroom	Primary current	Page 3
Pagina 4	Hoofdstroom	Primary current	Page 4
Pagina 5	Hoofdstroom	Primary current	Page 5
Pagina 6	Hoofdstroom	Primary current	Page 6
Pagina 7	Stuurstroom	Control voltage	Page 7
Pagina 8	PLC ingang 0CH00 - 07	PLC input 0CH00 - 07	Page 8
Pagina 9	PLC ingang 0CH07 - 15	PLC input 0CH07 - 15	Page 9
Pagina 10	PLC ingang 1CH00 - 07	PLC input 1CH00 - 07	Page 10
Pagina 11	PLC ingang 1CH08 - 15	PLC input 1CH08 - 15	Page 11
Pagina 12	PLC uitgang 100CH00 - 07	PLC output 100CH00 - 07	Page 12
Pagina 13	PLC uitgang 100CH00 - 15	PLC output 100CH00 - 15	Page 13

Betekenissen gebruikte afkortingen			
Draadkleuren			
brown 6mmq	bn6	brown 4mmq	bn4
blue 6mmq	bu6	blue 4mmq	bu4
black 6mmq	bk6	black 4mmq	bk4
green/yellow 6mmq	gnyw6	green/yellow 4mmq	gnyw4
brown 2mmq	bn2	brown 1,5mmq	bn1
blue 2mmq	bu2	blue 1,5mmq	bu1
black 2mmq	bk2	black 1,5mmq	bk1
green/yellow 2mmq	gnyw2	green/yellow 1,5mmq	gnyw1
brown 0,75mmq	bn	grey 0,75mmq	gy
black 0,75mmq	bk	yellow 0,75mmq	yw
green/yellow 0,75mmq	gnyw	purple 0,75mmq	pu
red 0,75mmq	rd	green 0,75mmq	gn
darkblue 0,75mmq	dbu	white 0,75mmq	wh
orange 0,75mmq	or		

Terminal strokes	
X1	Terminal stroke primary current
X2	Terminal stroke emergency stops and communication between machines
X3	Terminal stroke PLC input
X4	Terminal stroke PLC output
X23	Connector forklswitches

Cables	
W1	Cable motor conveyor belt
W2	Cable container transportmotor 1
W3	Cable container transportmotor 2
W4	Cable armmotor
W5	Cable pick-up motor
W10	Cable drive armmotor
W11	Cable drive pick-up motor
W12	Cable drive conveyor belt
W13	Cable brake armmotor
W19	Cable to back of the container switch
W20	Cable to container detection switches
W21	Cable to back of the container switch
W22	Cable pushbutton panel
W23	Cable forklswitches

1

3



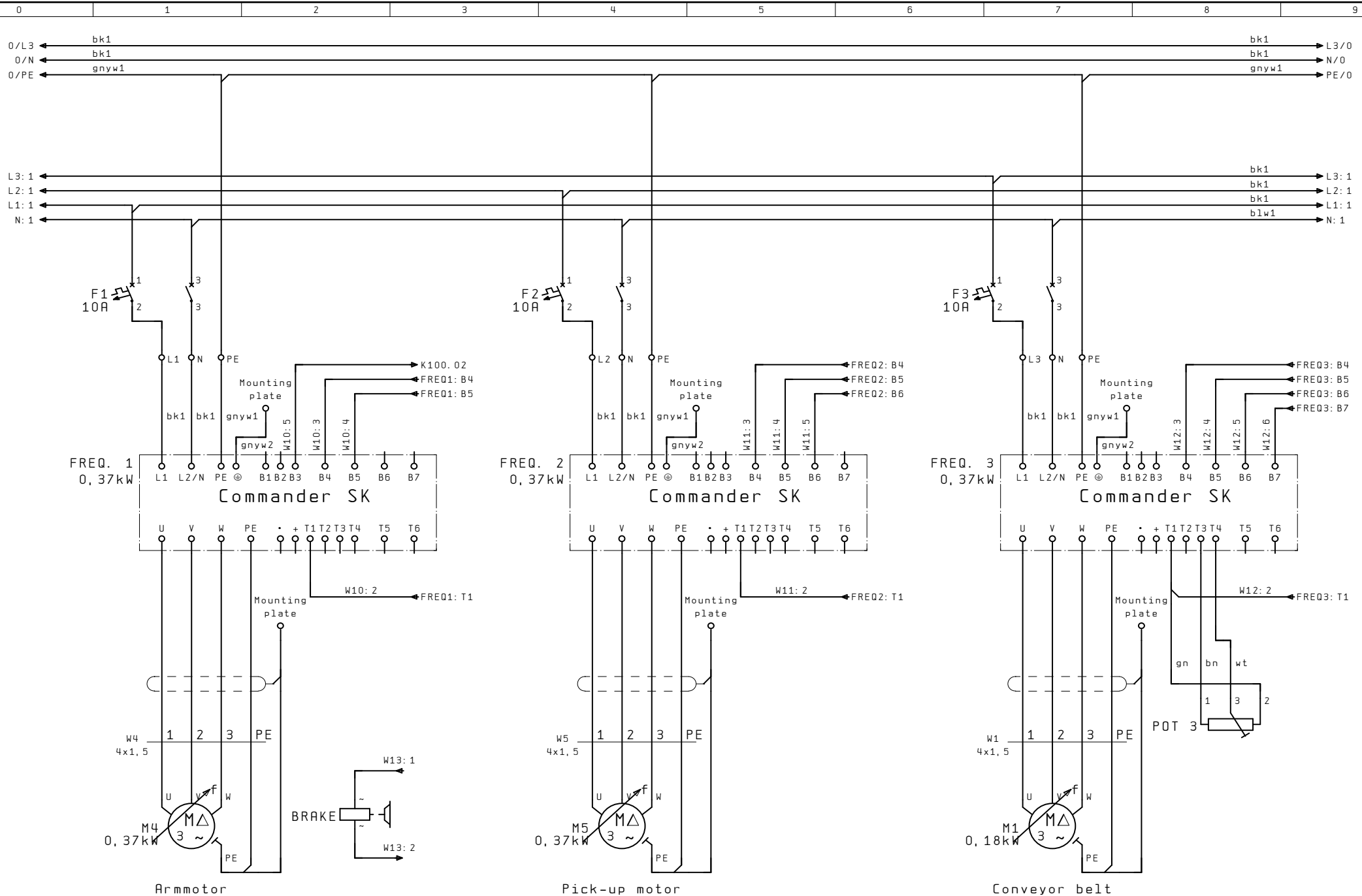

				Datum														
				Eng.	Wout Louter				Robot		TAVO		Hoofdstroom		Robot04F		=	
				Gez.	30. Mei. 2011						HOLLAND		Primary current				+	
Wijziging				Datum	Naam				Norm								B1. 4	
																13 B1		

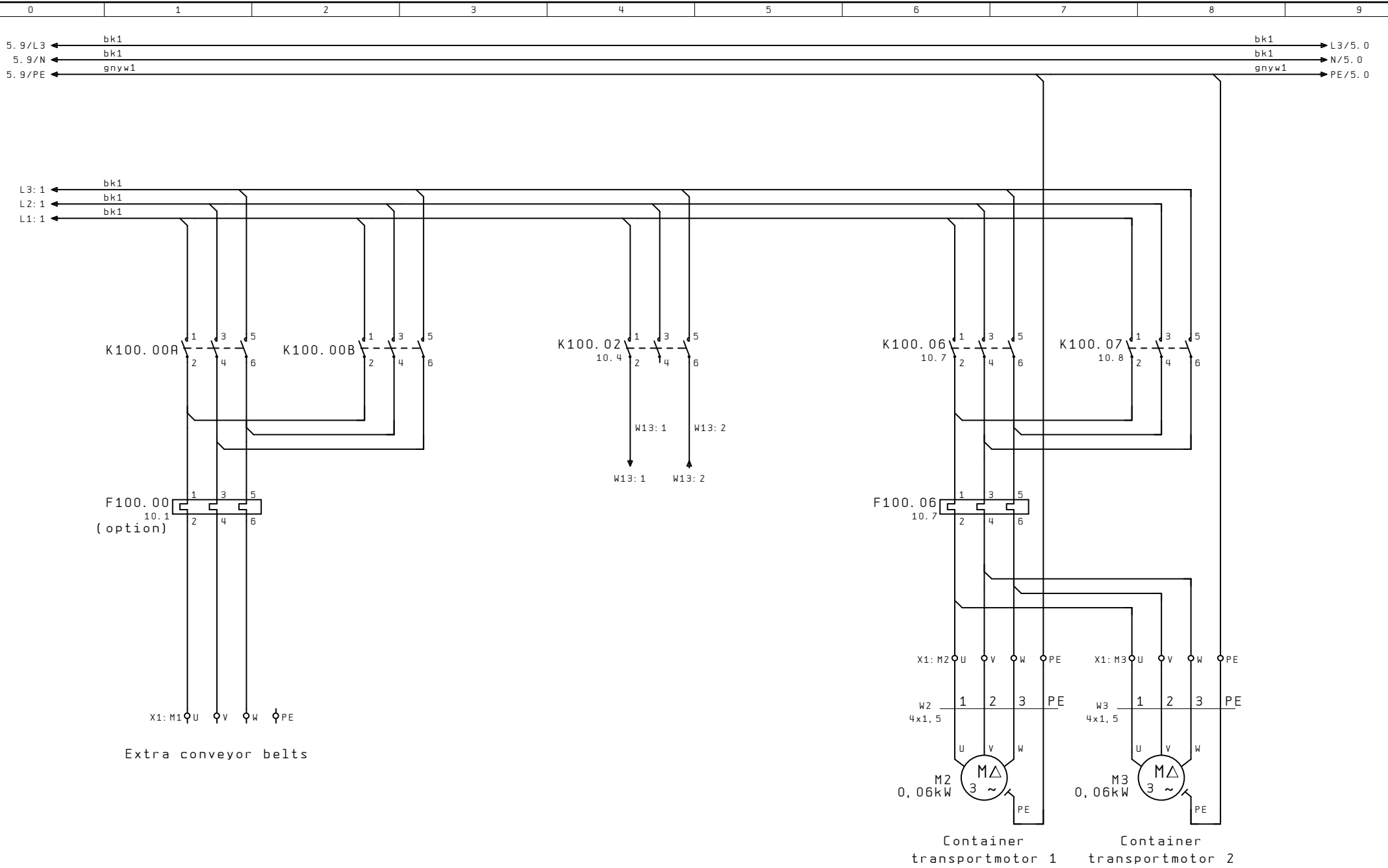

			Datum	
			Eng.	Wout Louter
			Gez.	30. Mei. 2011
Wijziging	Datum	Naam	Norm	

Robot



Hoofdstroom  
Primary current

Robot04F

=	
+	
	B1. 5
	13 B1

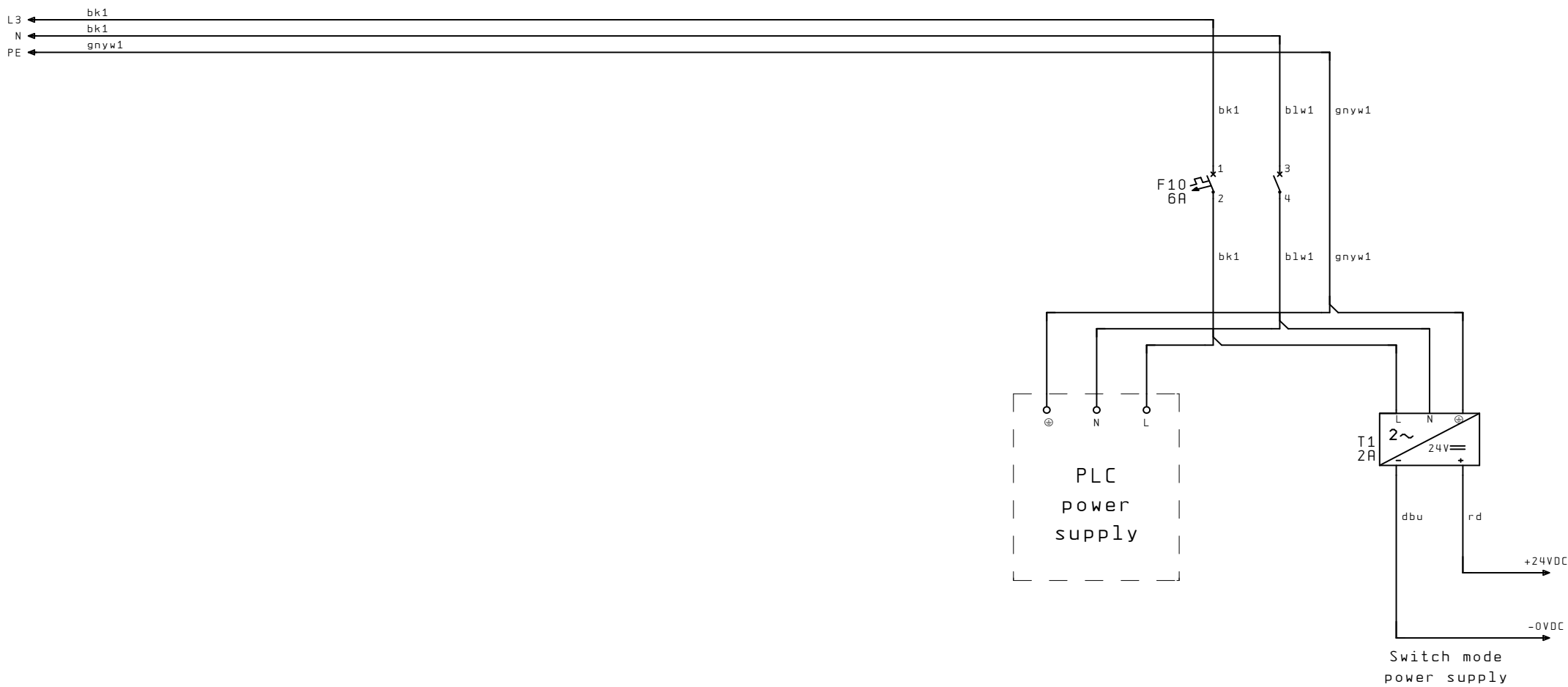

			Datum	
			Eng.	Wout Louter
			Gez.	30. Mei. 2011
Wijziging	Datum	Naam	Norm	

Robot



Hoofdstroom  
Primary current

Robot04F

=	
+	
	B1. 6
	13 B1.



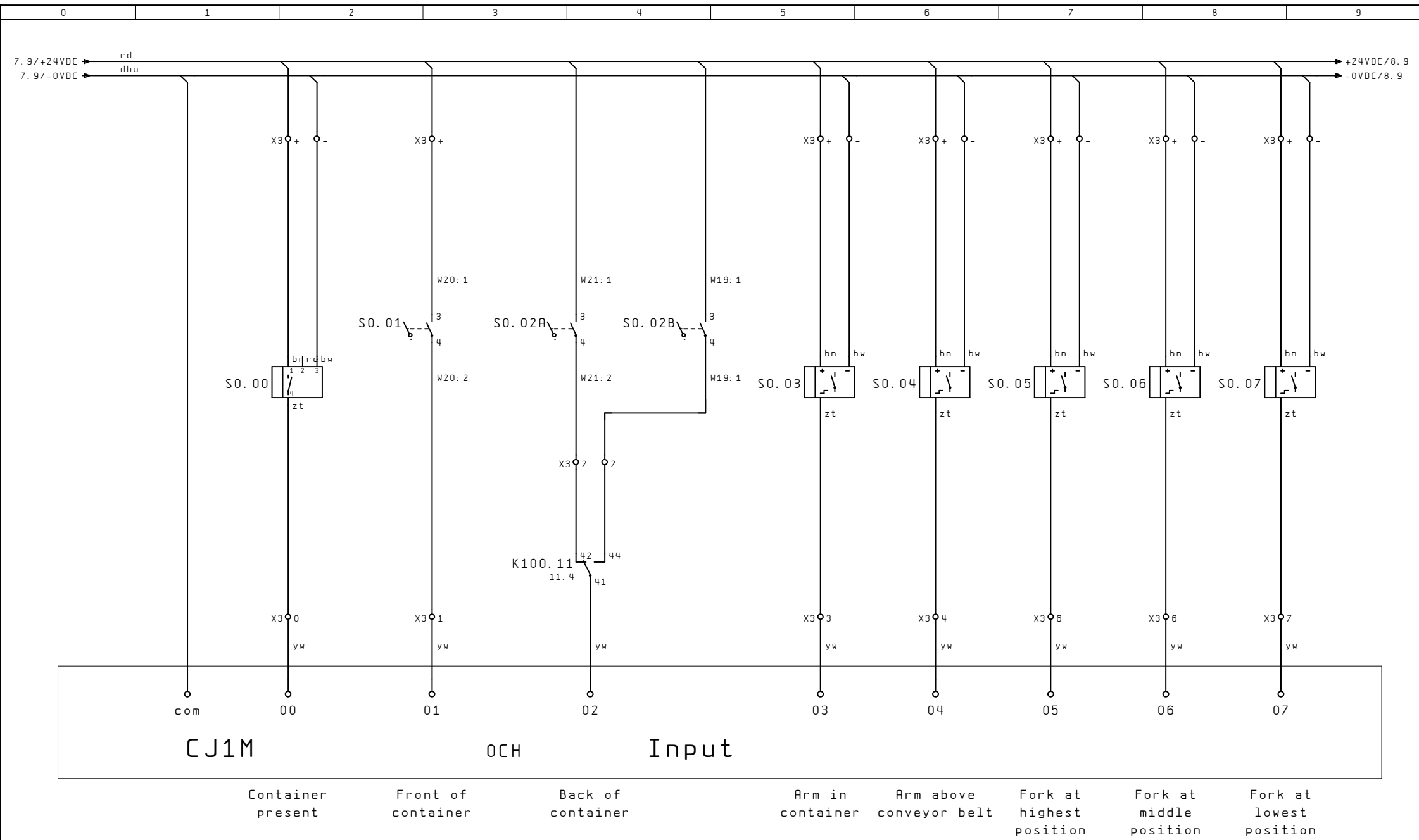

			Datum	
			Eng.	Wout Louter
			Gez.	30. Mei. 2011
Wijziging	Datum	Naam	Norm	

Robot



PLC ingang OCH00 - 07  
 PLC input OCH00 - 07

Robot04F

=	
+	
	B1. 8
	13 B1



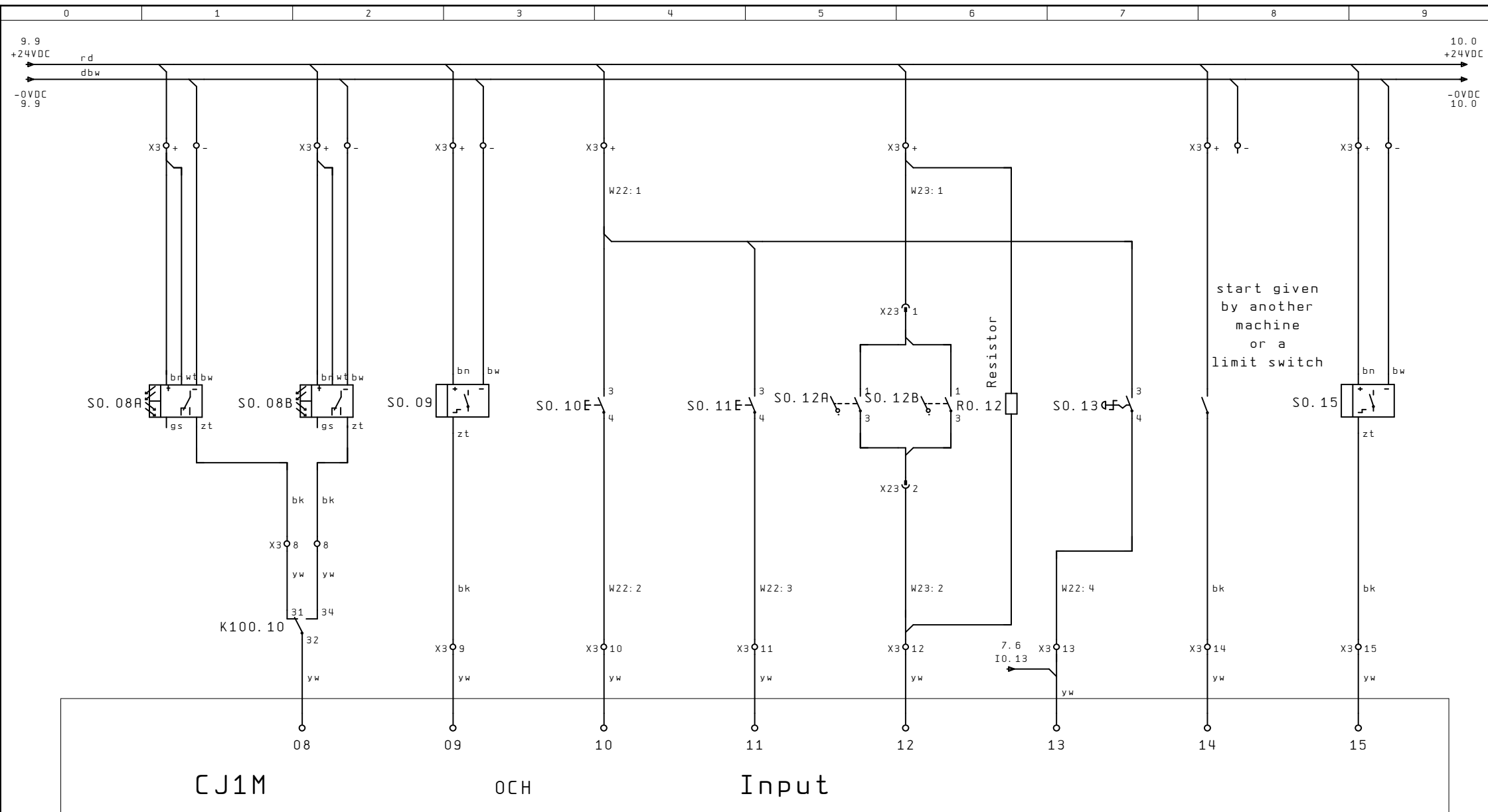

CJ1M

OCH

Input

- Potcounter
- Pulse counter  
container transport
- Stagger  
Pick-up  
robot
- Start to pick-up  
Pick-up  
robot
- Fork-  
switches
- Workstop
- Pots  
outfeed free  
pick-up  
robot
- Pulse counter  
conveyor belt

			Datum		<b>Robot</b>		PLC ingang OCH08 - 15 PLC input OCH08 - 15	Robot04F	=		
			Eng. Wout Louter							+	
			Gez. 30. Mei. 2011								
Wijziging	Datum	Naam	Norm							B1. 9 13 Bl.	

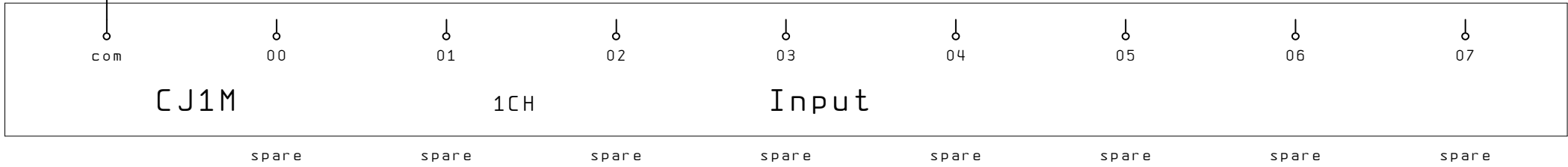
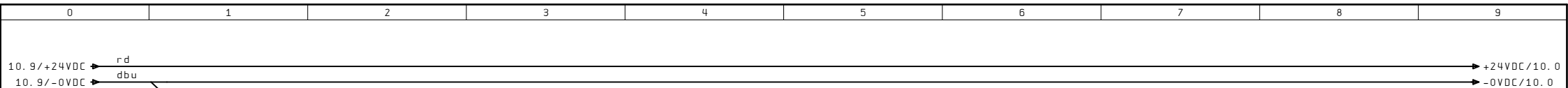

		Datum	
		Eng.	Wout Louter
		Gez.	30. Mei. 2011
Wijziging	Datum	Naam	Norm

Robot



PLC ingang 1CH00 - 07  
 PLC input 1ch00 - 07

Robot04F

=	
+	
	Bl. 10
	13 Bl.

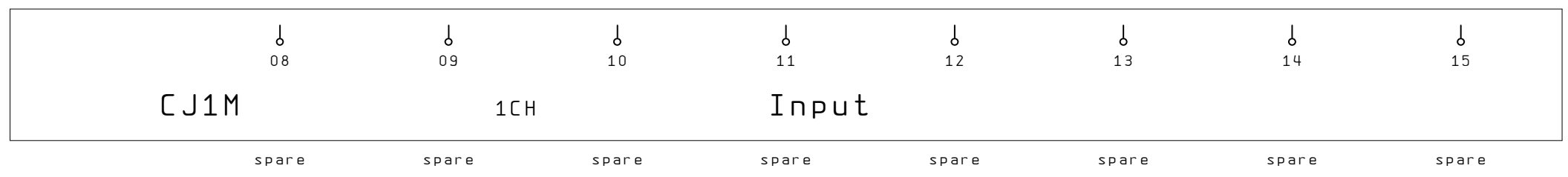
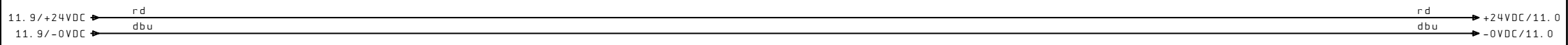

			Datum						
			Eng.	Wout Louter	Robot		PLC ingang 1CH08 - 15	Robot04F	=
			Gez.	30. Mei. 2011			PLC input 1Ch08 - 15		+
Wijziging	Datum	Naam	Norm						B1. 11 13 B1.

Conveyor belt forwards  
 Blockcylinder or Extra belts  
 pick-up robot (option)

Armmotor with brake

Pick-up motor forwards

Pick-up motor backwards

Stagger cylinder

Container transport motors forwards

Container transport motors backwards

CJ1M

2CH

Output

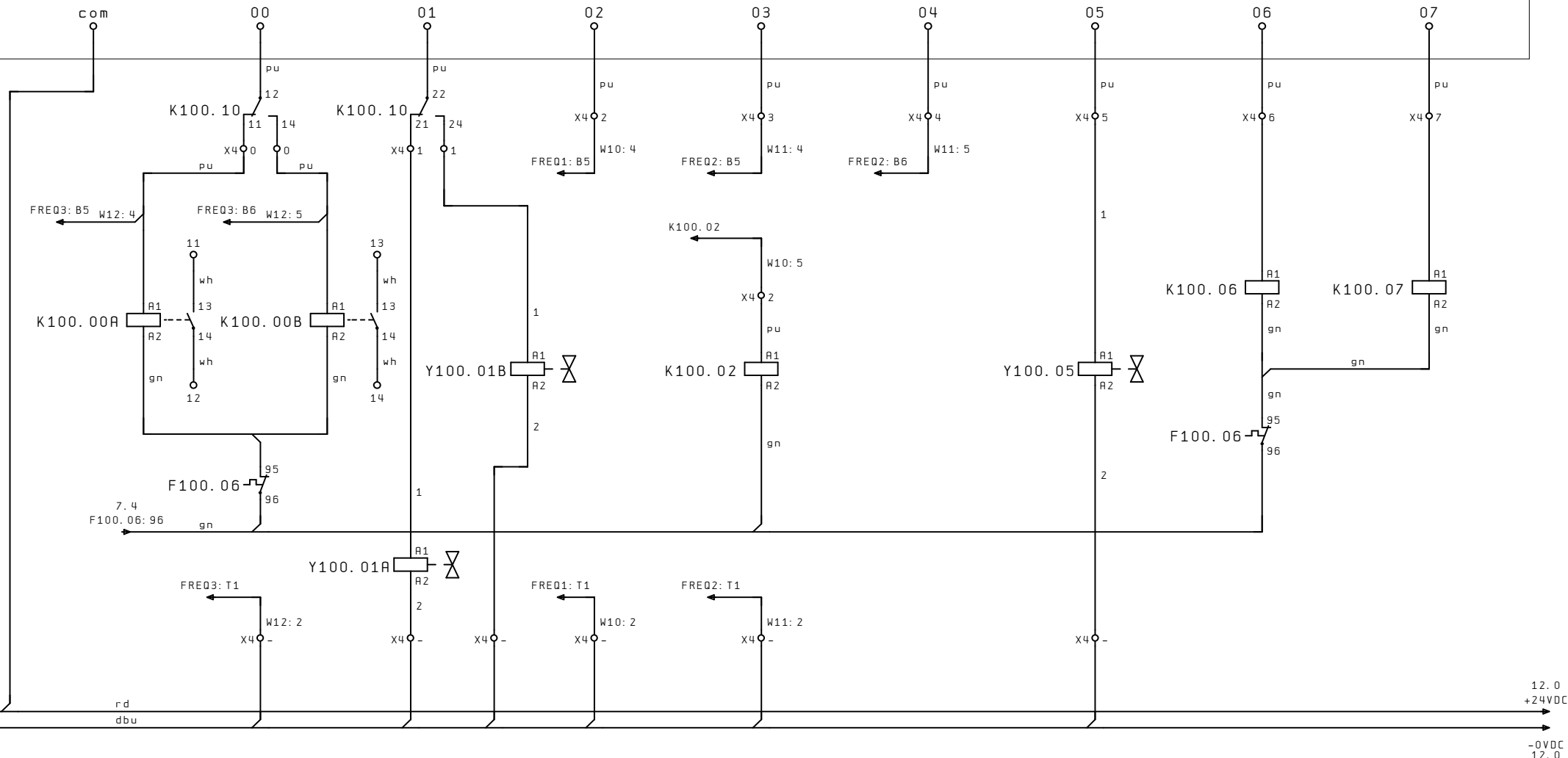

- 1 ~ 2 4.1
- 3 ~ 4 4.1
- 5 ~ 6 4.1
- 13 ~ 14 10.1

- 1 ~ 2 4.2
- 3 ~ 4 4.2
- 5 ~ 6 4.3
- 13 ~ 14 10.2

- 1 ~ 2 4.4
- 1 ~ 2 5.4
- 3 ~ 4 4.4
- 3 ~ 4 5.4
- 5 ~ 6 4.4
- 5 ~ 6 5.4

- 1 ~ 2 4.5
- 1 ~ 2 5.6
- 3 ~ 4 4.5
- 3 ~ 4 5.6
- 5 ~ 6 4.6
- 5 ~ 6 5.7

- 1 ~ 2 4.6
- 1 ~ 2 5.7
- 3 ~ 4 4.7
- 3 ~ 4 5.8
- 5 ~ 6 4.7
- 5 ~ 6 5.8

Datum				Robot				PLC uitgang 2CH00 - 07				Robot04F			
Eng. Wout Louter				TAVO HOLLAND				PLC output 2Ch00 - 07				=			
Gez. 30. Mei. 2011												+			
Wijziging Datum Naam Norm												B1. 12			
												13 B1.			

Clampcylinders  
(option)

Lift up  
cylinders  
(option)

Reverse  
course  
belt

Pick-up or  
Placing robot

Conveyor belt  
higspeed  
Pick-up robot

Blockcylinder  
"N-1"  
(option)

Trillmotor  
(option)

Ask new  
container  
(option)

CJ1M

2CH

Output

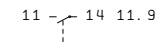
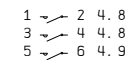
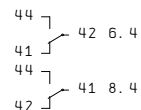
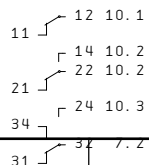
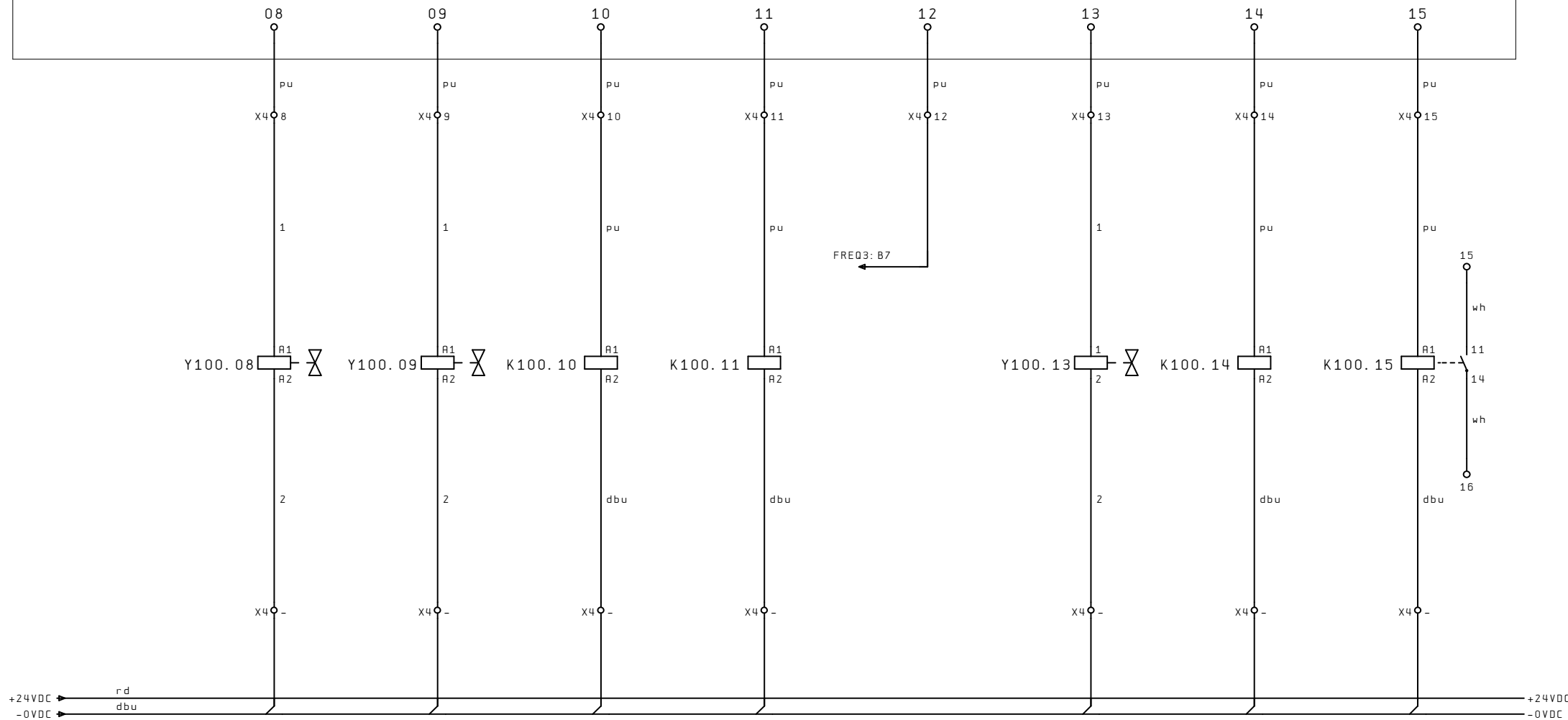

12

			Datum	
			Eng.	Wout Louter
			Gez.	30. Mei. 2011
Wijziging	Datum	Naam	Norm	

Robot



PLC uitgang 2CH08 - 15  
PLC output 2CH08 - 15

Robot04F

=	
+	
	B1. 13
	13 B1

Trädgårdsteknik AB  
Helsingborgsvägen Varalöv  
262 96 ÄNGELHOLM  
Tel: 0431-22290  
Fax: 0431-22270  
Mail: info@[tradgardsteknik.se](mailto:info@tradgardsteknik.se)  
Webb: [www.tradgardsteknik.se](http://www.tradgardsteknik.se)