



## UNIMAX (UNIM)

### **Specifications:**

Voltage	400Volt 50z 3~+N+ PE (N. America 208/220V. 60Hz)
Power connection machine	16A 3 phase 5pin
Power	1.1 kW
Length	3.260mm.
Width	1.300mm.
Height	1.990mm
Weight	±700kg
Capacity soil bin	1.500 liter (1.5m3)
Maintenance set	16A plug, 3x open end wrench, 1x door key
Turnable pot plate	2x adjustable in height from 500mm to 1000mm
Control machine	Foot switch, continuous switch, emergency stop

<b>Options:</b>	<b>Code:</b>	<b>Specifications:</b>
4 meter 5x1.5 cable incl. 16A plug	900965	
Continuos plug box	900966	Not standard
Soil bin extension	UNIMG	1200 Ltr extra
Heavy unmovable air wheels	SU1 L	
Electrical speed control on elevator	SU1E	Min. speed 25%, max. speed plus 20%
Adjustable sack holder	PMBVZ	
Turnable under plate	PMBDO	
Vibration unit complete	UNITR	Provided with a frequency control
* Extension set for Crate tilter	206-400	Excl. labour

### **Notes:**

\*Javo Crate tilter: cannot be placed on every position behind the Unimax, with the extension set it can.

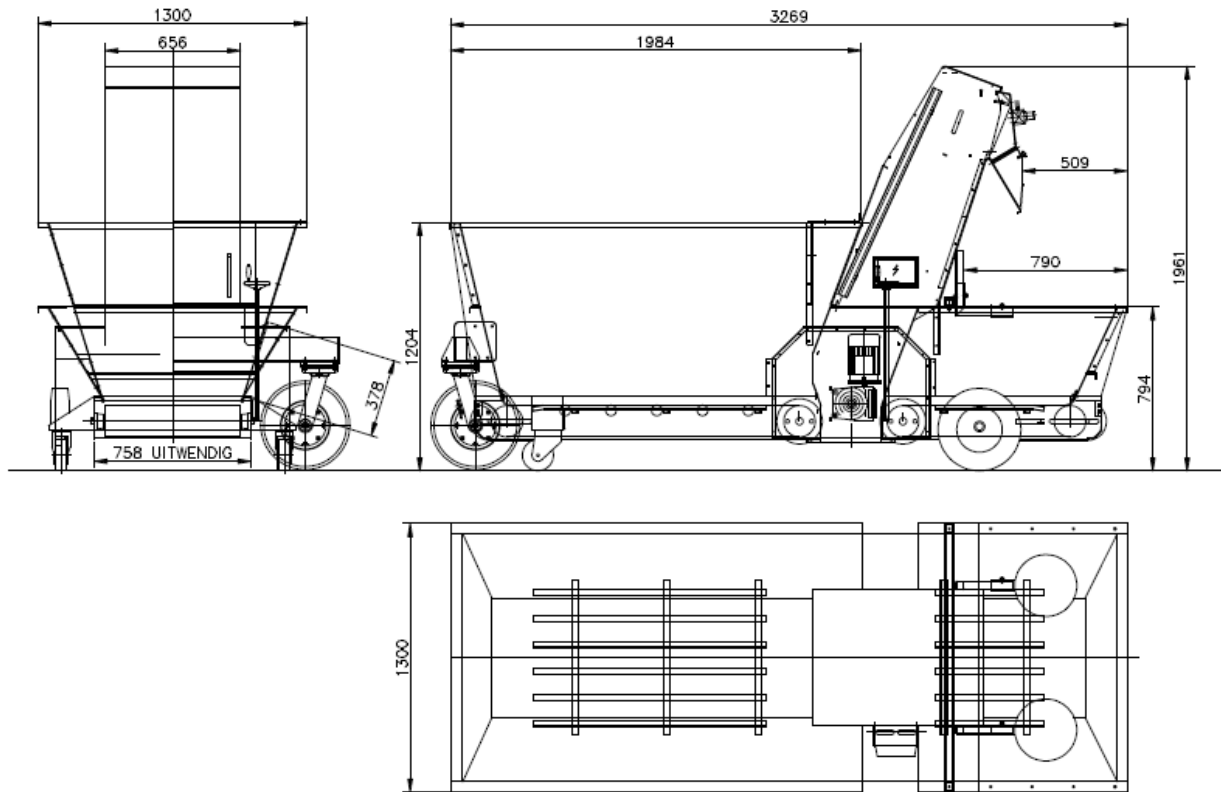

JAVO UNI-MAX

Project : Unimax  
Code : M\206  
Datum : 9 Jan 2004    Papier: A4  
Schaal : 1:25    Getekend: W.Steekers





Partner in Growing



# Newsletter

SUBJECT: Soil bin extension on the Unimax

DATE: 31-08-09

The soil bin extension type 206-400 will be used to make the back side of the Unimax suitable for a Crate Tilter.

To be able to mount this soil bin extension on the Unimax, both side plates of the big soil bin has to be grinded out as shown on the drawing UNI404-2

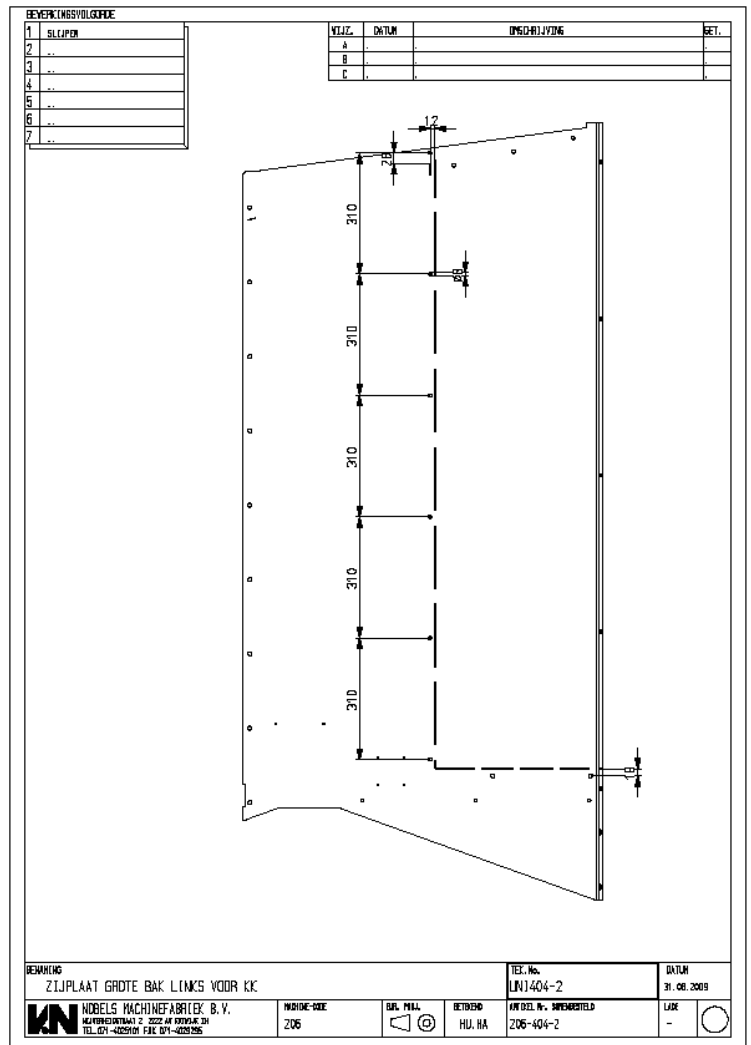
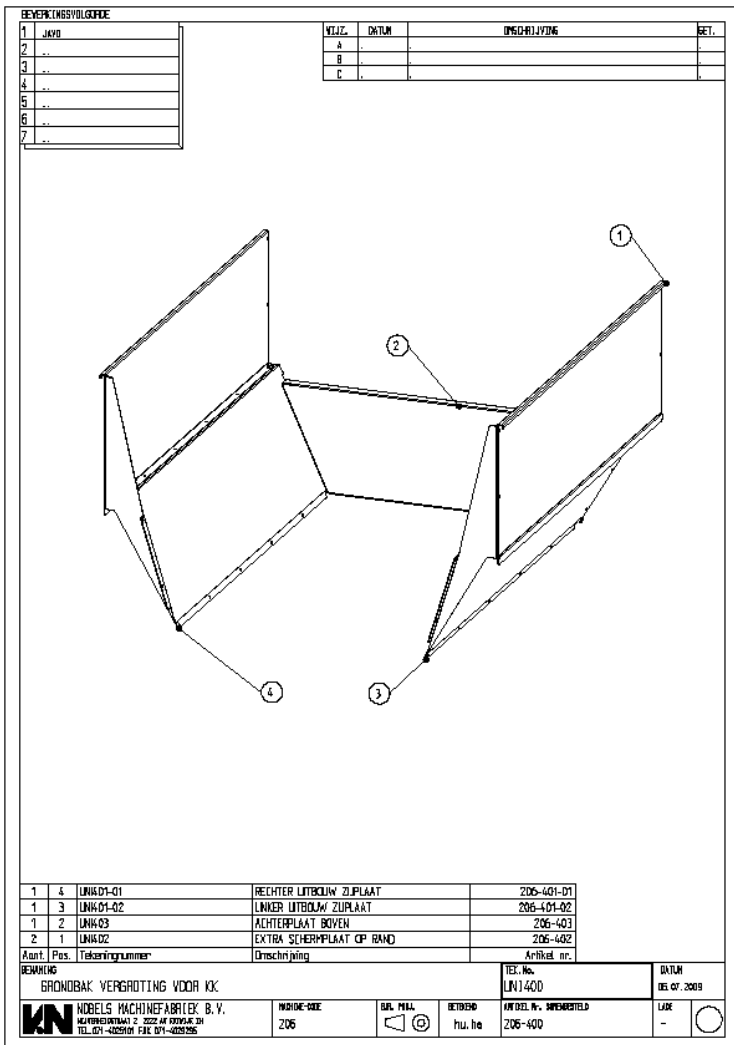



*Partner in Growing*



## ***Newsletter***

SUBJECT: Unimax

DATE: 28-2-11

From now on, the Javo Unimax will be delivered with soil-guiding-points in big soil bin. These points can be disassembled, so can also be added to existing machines.

Point large                      art. nr. 206-125

Point small                      art. nr. 206-126

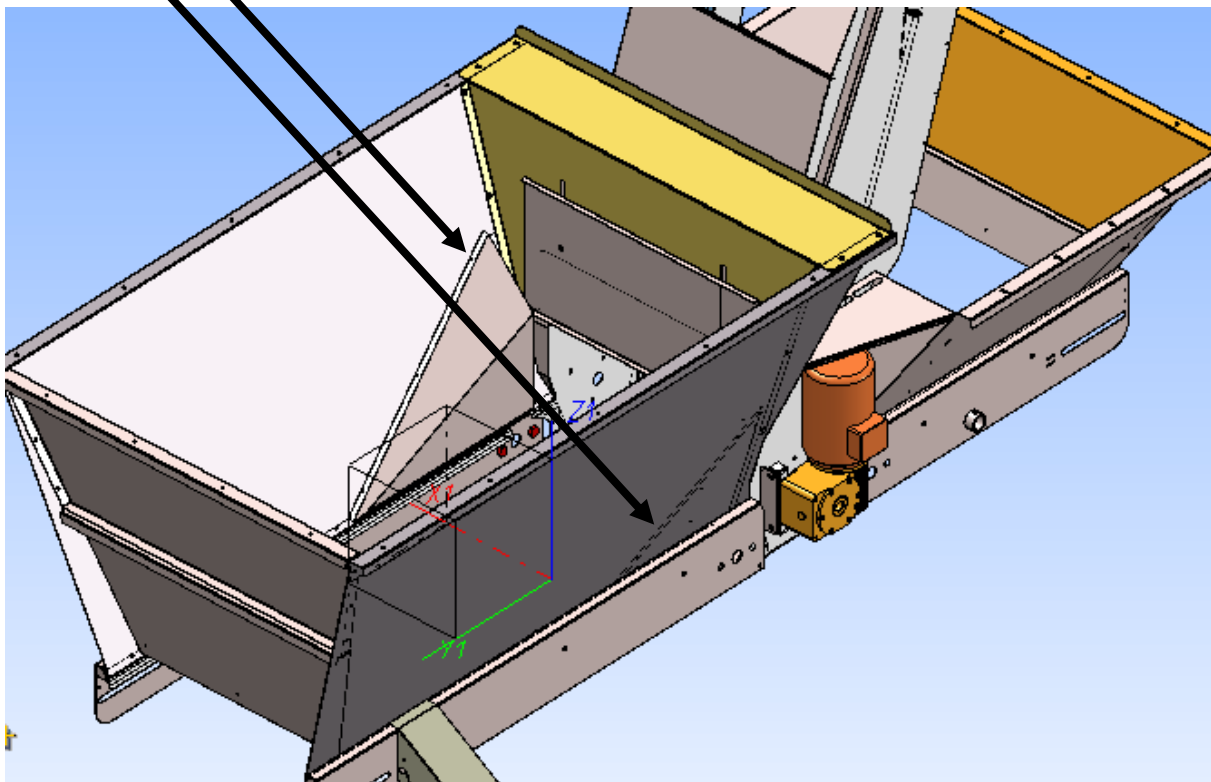

## Oil quantities (ccm) variable-speed ball drive KR1-KR4

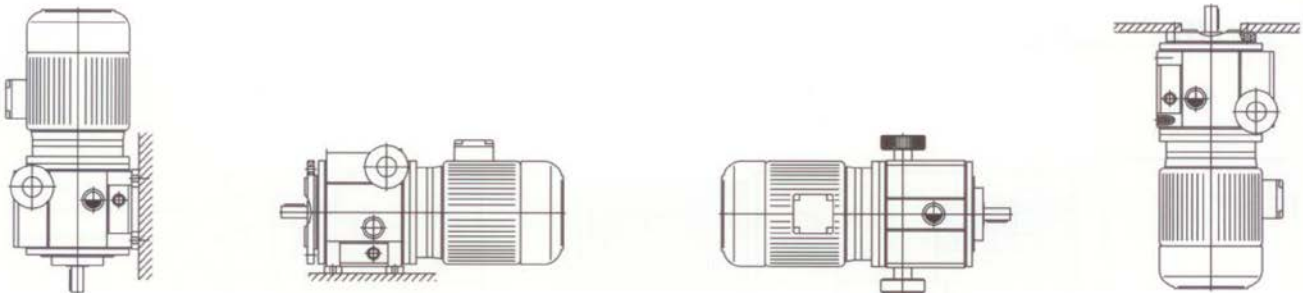

Einbaulage	V1, V5, V18	B3, B5, B14	B6, B7	V3, V6, V19
KR1	70	70	70	70
KR2	200	125	200	125
KR3	400	250	400	250
KR4	800	450	800	450

*Only the use of Santotrac 50/Variotrac 32 synthetic traction fluid ensures full power transmission.*

*The warranty requires this oil type to be used. The oil should be changed after 5000 operating hours (at least once per year). The oil change must not be carried out during operation. No other maintenance work is required.*

## Oil quantities FMRV + FDL:

Drive:	Quantity (ltr):	Type:
FMRV030	0,05	BP Energol SG-XP320
FMRV040	0,1	BP Energol SG-XP320
FMRV050	0,15	BP Energol SG-XP320
FDL018	0,13 (aber in vertikal mit Wellenende nach unten: 0,2)	BP Autran DX
FDL037	0,15 (aber in vertikal mit Wellenende nach unten: 0,25)	BP Energol SG-XP320

Trädgårdsteknik AB  
Helsingborgsvägen Varalöv  
262 96 ÄNGELHOLM  
Tel: 0431-22290  
Fax: 0431-22270  
Mail: info@[tradgardsteknik.se](mailto:info@tradgardsteknik.se)  
Webb: [www.tradgardsteknik.se](http://www.tradgardsteknik.se)